

DB3062.200 / DB3062.250 / DB3062.300 / DB3062.350

DOLPHIN BLUE WALL MOUNTED SHOWER ARM

INSTALLATION AND MAINTENANCE GUIDE

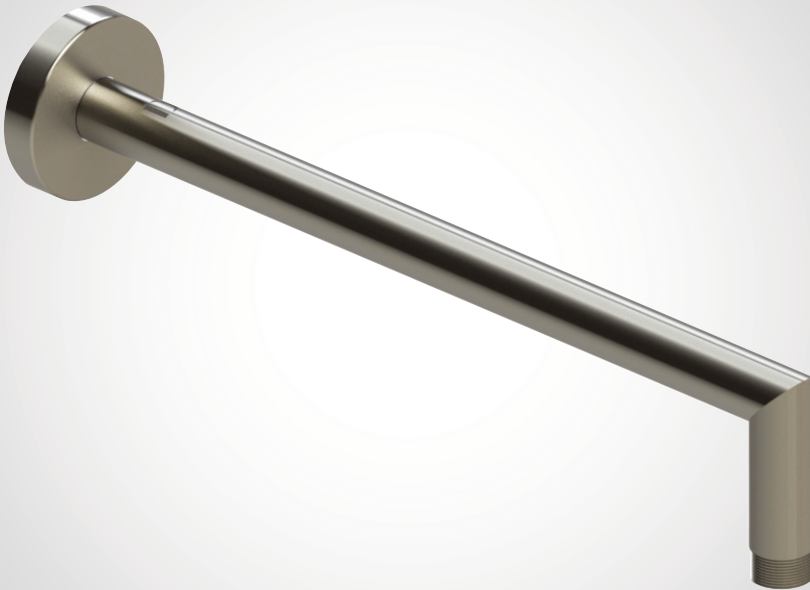

April 2020



DIMENSIONS

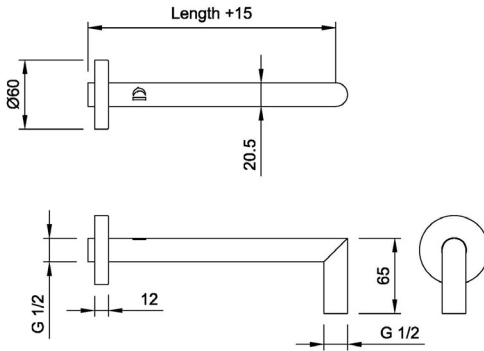

Product code	Length
DB3062.200	200mm
DB3062.250	250mm
DB3062.300	300mm
DB3062.350	350mm

MAIN COMPONENTS

Reference Description

- 1 Arm
- 2 Rosette
- 3 Sealing washer (not shown)



- > To check the product suitability for commercial and multiple installations, please contact Dolphin Solutions' specification advisory service before installation.
- > INSTALLERS PLEASE NOTE THESE INSTRUCTIONS ARE TO BE LEFT WITH THE USER

INSTRUCTIONS

INTRODUCTION

- › Please read these fitting instructions carefully before beginning your installation.
- › The shower installation must be carried out by a suitably competent person and in sequence of this instruction book.
- › Care taken during the installation will give a long and trouble free life from your shower arm.

SITE REQUIREMENTS

- › The installation must be in accordance with water supply (water fittings) regulation 1999 and/or local Bylaws.

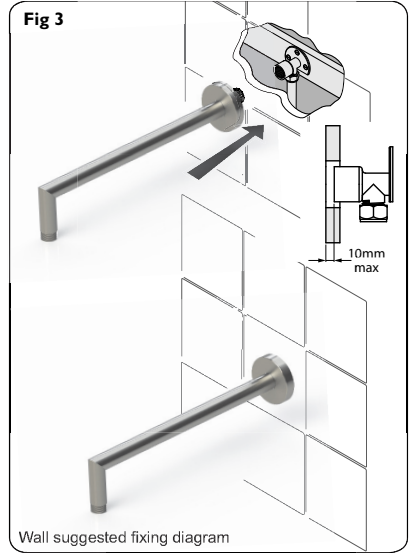

INSTALLATION

- › Install the adapter into a suitable fitting (*wall plate elbow, or similar with a minimum of 3 fixing screws) ensuring that the flush fitting pipework has suitable support.
- › **NOTE:** It is not advisable to fix the arm through the plasterboard alone, please consider a strong rear support. A maximum guide dimension of 10mm is given from the rear of the adapter to the face of the exterior wall (fig.3).
- › When the pipe work fitting is secure and the wall is made good, carefully screw the shower arm onto the fitting. The shower arm may need adjustments to fit flush against the wall. The thread can be trimmed to suit.
- › Use of PTFE tape on the arm threads is advised to ensure a seal. Check the installation is leak tight.

WARNING!

- › Check there are no hidden cables or pipes before drilling holes. Use great care when using power tools near water. The use of a residual current device (RCD) is recommended.

APPROVALS

This shower arm has the following approvals

- › WRAS

LIMITED WARRANTY

Dolphin Solutions Ltd warrants that its electronic taps, flush valves and controls will be free of defects in material and workmanship during normal use for two years from the date the product is purchased.

If a defect is found in normal use, Dolphin Solutions Ltd will, at its discretion, repair, provide a replacement part or product, or make appropriate adjustments. Damage caused by accident, misuse, or abuse is not covered by this warranty. Improper care and cleaning will void the warranty. Proof of purchase (original sales receipt) must be provided to Dolphin Solutions Ltd with all warranty claims. Dolphin Solutions Ltd is not responsible for labour charges, installation, or other incidental or consequential costs other than those noted above. In no event shall the liability of Dolphin Solutions Ltd exceed the purchase price of the tap, valve or control.

If you believe that you have a warranty claim, contact your Dolphin Distributor, Dealer or Plumbing Contractor. Please be sure to provide all pertinent information regarding your claim, including a complete description of the problem, the product, model number, the date the product was purchased, from whom the product was purchased and the installation date. Also include your original invoice.

DOLPHIN SOLUTIONS LTD AND/OR SELLER DISCLAIM ANY LIABILITY FOR SPECIAL, INCIDENTAL OR CONSEQUENTIAL DAMAGES. This warranty excludes product damage due to installation error; incorrect maintenance, wear and tear; battery, water composition, product abuse, or product misuse, whether performed by a contractor, service company, or the consumer. This warranty does not cover product damage caused by the following:

- > Incorrect installation, inversions of supply pipes.
- > Pressures or temperatures exceeding recommended limits.
- > Improper manipulation, tampering, bad or lapsed maintenance.
- > Foreign bodies, dirt or scale introduced by the water supply.

DOLPHIN SOLUTIONS LIMITED reserve the right to change product specification without prior notice.

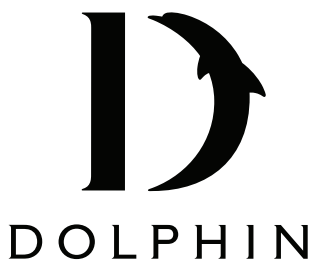

Dolphin Solutions Ltd

Southpoint, Compass Park, Bodiam,
Robertsbridge, TN32 5BS

Tel: +44 (0)1424 20 22 24

Fax: +44 (0)1424 205 200

info@dolphinsolutions.co.uk

www.dolphinsolutions.co.uk