

DB840 / DB850 / DB850 / DB875

DOLPHIN COUNTER MOUNTED INFRARED TAP

INSTALLATION AND MAINTENANCE GUIDE



October 2019



INDEX

3	Technical Data
4	Pack Contents
5	Pre Installation Information
6-7	Tap Installation
8-10	Settings Adjustment
11	Battery Replacement Instructions
12	Maintenance Filter Cleaning Instructions Care And Cleaning Of Chrome And Special Finishes
13	Trouble-Shooting
14	Spare Parts List
15	Limited Warranty

TECHNICAL DATA

Power Supply:	9V battery or 9V transformer
Min Operating Water Pressure:	0.5 bar(7 PSI)
Max Operating Water Pressure:	8.0 bar(116 PSI) With water pressure of more than 8 Bars, use a pressure reducing valve
Sensor Range:	Self adjusting sensor
Minimum Sensor Range:	50mm.
Maximum Sensor Range:	160 mm.
Security time:	90 seconds. Can be reduced with the remote control

TECHNICAL DATA

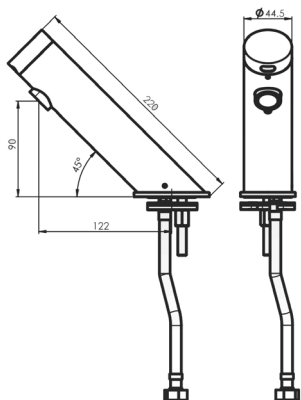

DB840

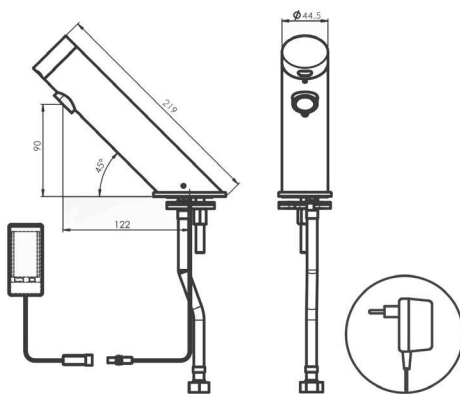

DB845

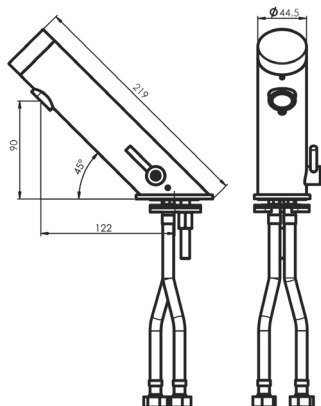

DB850

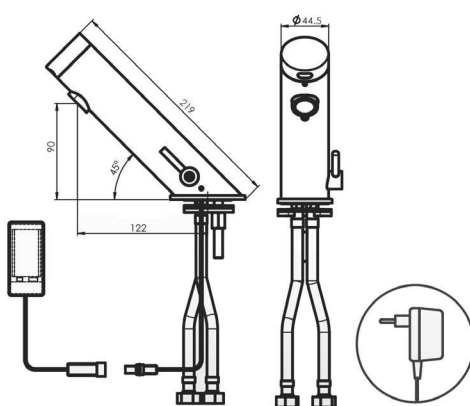

DB875

PACK CONTENTS

Familiarise yourself with the part names and confirm that the parts are included

DB840

1 x Tap and attachments
with internal
battery

1 x Allen Key

1 x filter

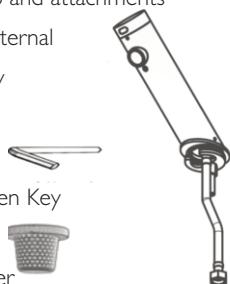

DB845

1 x Tap and
attachments

1 x Allen Key

1 x filter

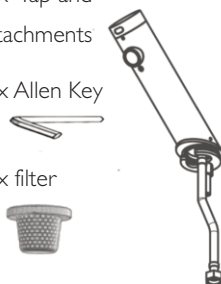

DB840
67 Battery
Box



DB845
Transformer

DB850

1 x Tap and
attachments with
internal battery

1 x Allen Key

2 x filters

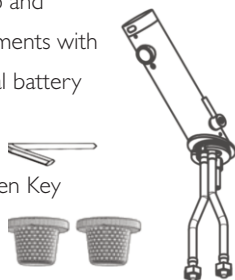

DB875

1 x Tap and
attachments

1 x Allen Key

2 x filters

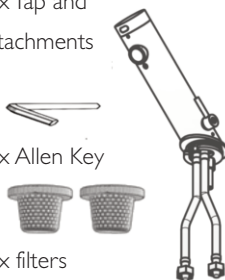

DB850
67 Battery
Box



DB875
Transformer

PRE INSTALLATION INFORMATION

CHECK CONTENTS

- › Separate all parts from packaging and check each part with the pack contents section. Pay attention to the different models variations.
- › Make sure all parts are accounted for before discarding any packaging material. If any parts are missing, do not attempt to install this electronic tap until you obtain the missing parts.

WARNINGS:

- › Highly reflective surfaces directly beneath the sensor of this product, in particular polished finish basin wastes / strainers, will cause false activation of the infrared sensors and can result in malfunction. We recommend satin or matt finish products which can be found on our website.
- › Do not install the tap facing a mirror or any other electronic system operated by an infra-red sensor. To prevent reflection problems, it is recommended to keep a minimum distance of 1.50 meters between the tap and other objects.

PREPARATION FOR INSTALLATION

- › Flush water supply lines thoroughly before installing the tap. Do not allow dirt, Teflon tape or metal particles to enter the tap.
- › Shut off water supply.

IMPORTANT:

- › All plumbing is to be installed in accordance with applicable codes and regulations.

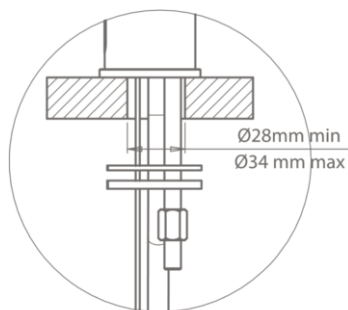

Recommended hole size

TAP INSTALLATION

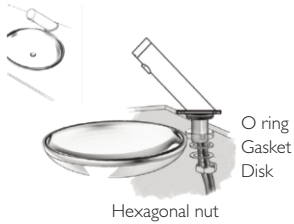

STEP 1 - REMOVE ALL MOUNTING HARDWARE

Shut off water supply and remove the hexagonal nut, the disk and the gasket. Do not remove the O-ring from the base of the tap.

STEP 2 - INSTALLING THE TAP

1. Place the tap with O-ring into the hole in deck or lavatory. Make sure the O-ring is located between the deck or lavatory and the bottom of the tap.
2. Slide the gasket over the flexible hose.
3. Secure the tap to deck or lavatory with the hexagonal nut and the disk.

STEP 3 - CONNECTING THE WATER SUPPLY

1. a. For DB840 and, DB845: Connect the flexible pipe to the water supply.
b. For DB850 and DB875: Connect the red flexible pipe to the hot water supply and the blue pipe to the cold water supply.
2. Make sure that the filter/s is/are installed between the flexible pipe and the shut off valve (not supplied).
3. Turn on the central water supply and the shut-off valve/s.
4. Check for leaks.

STEP 4 - CONNECTING THE POWER SOURCE

This product includes a self adjusting sensor: The ideal sensor range for the specific location will be set automatically.

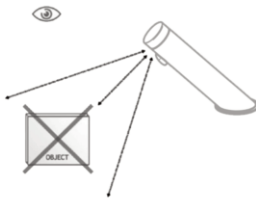

Important: Check that no objects are in front of the sensor besides the washbasin.

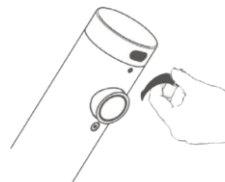

Now remove the protecting sticker that covers the sensor.

TAP INSTALLATION

If your model is DB840 or DB850:

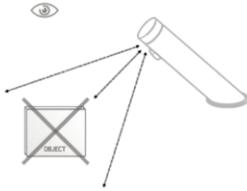

Important: Check that no objects are in front of the sensor besides the washbasin.

Now remove the protecting sticker that covers the sensor.

Install the battery's box at the wall underneath the sink using the two sided adhesive foam facet. The cable connection must point down. (You can use an optional extension cable in order to assemble the battery box up to 10ft. away from the sink.)

4. If your model is DB845 or DB875: Plug the transformer into the electricity socket and connect the connectors.
5. Wait about 5 seconds in order to allow the system to set the ideal sensor range. After the self adjustment has taken place the solenoid valve will be opened and closed for 1 second. As an indication, you will see a small amount of water delivered from the spout. Then the product will be ready for use.
6. If the obtained range is unsatisfactory, refer to the section entitled "Range adjustment".



Note: This tap includes a special aerator that allows you to adjust the water stream direction on site in order to prevent water splashing if needed. To change the angle of the water stream, simply move the adjustable tilting plate by pressing it smoothly.

SETTING ADJUSTMENT



ADJUSTING THE SENSOR WITH THE REMOTE CONTROL

If necessary, the sensor settings can be adjusted as following:

Shut off the water supply. In order to adjust the sensor with the remote control, hold the remote control straight in front of the sensor in a distance of about 6-8" (15-20cm). Choose the function you want to adjust by pressing once on one of the function buttons. After pressing once on a specific function button, a quick flashing of the red light at the front of the sensor will occur. At this stage, you can change the setting by pressing the (+) or the (-) buttons, every push will increase or decrease one level. After finishing the adjustment, turn the water supply back on.

RANGE ADJUSTMENT



DETECTION RANGE: This tap was supplied with a Self Adjusting Sensor. The ideal detection range for the specific location will be set automatically. **Only if necessary**, use the remote control to adjust the sensor range as follows:

Press the RANGE button. Wait until a quick flashing of the red light of the sensor eye is perceived. Then, press + to increase the one level and – to reduce it every push will increase or decrease one level.

Note: Once you have changed the detection range with the remote control, this distance will be remembered by the sensor, even if the power source is disconnected. To get back to the self adjustment mode, use the ADJ button only.



ENTRANCE TO THE SELF ADJUSTMENT MODE: Check that no objects are in front of the sensor. Press the ADJ button. Once a quick flashing of the red light of the sensor eye is perceived, remove your hand holding the remote control and move away from the sensor area. The ideal sensor range for the specific location will be set automatically. Once the self adjustment has taken place the solenoid valve will be opened and closed for 1 second as an indication that the ideal sensor range was set and the product is ready for use.



SECURITY TIME: The Security time, prevents continuous running of water due to reflections or vandalism. By default, if the sensor is covered for more than 90 seconds the water flow will shut automatically. To resume regular operation any obstruction must be removed.

Press the SEC button. Wait until a quick flashing of the red light of the sensor eye is perceived. Then, press + to increase the security time and - to reduce it.

RANGE ADJUSTMENT



DELAY IN TIME: It is recommended to change the delay in time for flush valves for urinals or toilets only.

If required, the delay in time can also be modified in taps as follows: Press the IN button. Wait until a quick flashing of the red light of the sensor eye is perceived. Then, press + to increase the delay in time and - to reduce it.



DELAY OUT TIME: This button allows modifying the water flow time after the user removes his hands from the tap. A delay out time close to 0 will save more water. An increased delay out time will make the user experience more comfortable.

If required, the delay out time can be modified as follows: Press the OUT button. Wait until a quick flashing of the red light of the sensor eye is perceived. Then, press + to increase the delay out time and - to reduce it.



TEMPORARY OFF FUNCTION: This function is ideal to perform any kind of activity in front of the sensor without operating the system (for example, cleaning). The tap will remain shut for 1 minute when this button is pressed once. To cancel this function and to return to normal operation press the On/Off button again or wait 1 minute.



RESET BUTTON: This function restores all the factory settings except for the sensor range. If required, press the Reset button and without releasing it, press the + button once.

Note: To enter the self adjusting mode, use the ADJ button. To change the sensor range, use the RANGE button.

BATTERY REPLACEMENT

When the battery weakens, the red indicator light will blink at a constant rate. The battery must be replaced within two weeks.

TO REPLACE THE BATTERY IN DB840, DB850

- 1 Carefully open the battery's box.
- 2 Remove the old battery.
3. Replace the used battery with a new 9 v battery. A lithium battery is recommended.
- 4 Close the box.

BATTERY REPLACEMENT

Note: If you did not change the sensor detection range with the remote control, the system will perform a new self adjustment after the reconnection of the battery.

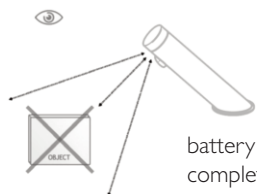

Check that there are no objects in front of the sensor after the battery replacement was completed.



After you have replaced the battery, move away from the sensor range. Wait 5 seconds in order to allow the system to set the ideal sensor range. Then after the self adjustment has taken place the solenoid valve will be opened and closed for 1 second as an indication that the ideal sensor range was set and the product is ready for use.



Important: Spent batteries should not be disposed of with normal household waste. Contact your local authority for information on waste disposal and recycling.

MAINTENANCE

Filter cleaning instructions

This tap is provided with one or two stainless steel filter/s preventing foreign particles to enter the lines. If the water flow has decreased, this may be because the filter is clogged. The filter can be cleaned as follows:

- 1 Shut-off the water shutoff valve.
- 2 Disconnect the flexible pipe.
- 3 Remove the filter/s and wash it/them under running water.
- 4 Reassemble the parts.
- 5 Reconnect the flexible pipe and restore the incoming water supply.
- 6 Make sure that there is no water leakage.

CARE AND CLEANING OF CHROME AND SPECIAL FINISHES

DO NOT use steel wool or cleansing agents containing alcohol, acid, abrasives, or the like. Use of any prohibited cleaning or maintenance products or substances could damage the surface of the tap. For surface cleaning of taps use **ONLY** soap and water; then wipe dry with clean cloth or towel. When cleaning bathroom tile, the taps should be protected from any splattering of harsh cleansers.

TROUBLE SHOOTING

PROBLEM	INDICATOR	CAUSE	SOLUTION
No water coming out of the tap:	1. Sensor flashes continuously when user's hands are within the sensor's range.	Low battery.	Replace battery.
	2. Red light in the sensor does not flash when user's hands are within the sensor's range.	1. Inappropriate detection range.	Adjust using the remote control. Alternatively you can take out the battery and place it again to perform a new sensor self adjustment (page 9).
		2. Battery is completely used up	The battery must be replaced.
Water flow from spout does not stop:	3. Red light in the sensor flashes when user's hands are within the sensor's range.	3. Unit is in "Security Mode"*	Eliminate cause of reflection.
		4. Sensor is picking up reflections from the washbasin or another object.	Eliminate cause of reflection.
		1. Connectors between the electronic unit and solenoid are disconnected.	Connect the electronic unit connectors to the solenoid.
		2. Debris or scale in solenoid.	Replace solenoid.
	1. Sensor flashes when user's hands are within the sensor's range	3. The water supply pressure is higher than 8 bar.	Reduce the supply water pressure.
4. The water supply pressure is under 8 bars and yet the pressure in the faucet's body is higher. This situation could be caused by a sudden increase in the water supply pressure that the back-check prevents from dropping, even after water supply pressure drops under 8 bars.		Shut off water supply and unscrew one of the flexible pipes in order to reduce the pressure that is blocked in the product.	
Water flow diminished	2. Red light in the sensor does not flash when user's hands are within the sensor's range	Debris or scale in solenoid.	Replace solenoid.
		Sensor is picking up reflections from mirror or another object.	Decrease the detection range using the remote control. Alternatively you can take out the battery and place it again to perform a new sensor self adjustment (page 9).
			Remove, clean, re-install

* "Security Mode": If the sensor is covered for more than 90 sec. the faucet will automatically shut off water flow. To return to normal operation remove any blockage to re-establish operation.

SPARE PARTS LISTING

DB840, DB845: Part Name	Part Code
Interoperable Solenoid Valve	DB07500065
Seals and Screws Kit	DB07210082
Cover Kit	DB07270106
Nano Sensor	DB08004006
9V Battery box	DB06520008
9V Transformer	DB06522042
IP67 Battery box.....	DB06530020
IP67 Box with Transformer	DB06530021

DB850, DB875: Part Name	Part Code
Interoperable Solenoid Valve	DB07500065
Seals and Screws Kit	DB07210083
Cover Kit	DB07270106
Nano Sensor	DB08004006
Mixing Handle kit	DB07260008
9V Battery box	DB06520008
9V Transformer	DB06522042
IP67 Battery box	DB06530020
IP67 Box with Transformer.....	DB06530021

LIMITED WARRANTY

Dolphin Solutions Ltd warrants that its electronic taps, flush valves and controls will be free of defects in material and workmanship during normal use for two years from the date the product is purchased.

If a defect is found in normal use, Dolphin Solutions Ltd will, at its discretion, repair, provide a replacement part or product, or make appropriate adjustments. Damage caused by accident, misuse, or abuse is not covered by this warranty. Improper care and cleaning will void the warranty. Proof of purchase (original sales receipt) must be provided to Dolphin Solutions Ltd with all warranty claims. Dolphin Solutions Ltd is not responsible for labour charges, installation, or other incidental or consequential costs other than those noted above. In no event shall the liability of Dolphin Solutions Ltd exceed the purchase price of the tap, valve or control.

If you believe that you have a warranty claim, contact your Dolphin Distributor, Dealer or Plumbing Contractor. Please be sure to provide all pertinent information regarding your claim, including a complete description of the problem, the product, model number, the date the product was purchased, from whom the product was purchased and the installation date. Also include your original invoice.

DOLPHIN SOLUTIONS LTD AND/OR SELLER DISCLAIM ANY LIABILITY FOR SPECIAL, INCIDENTAL OR CONSEQUENTIAL DAMAGES. This warranty excludes product damage due to installation error; incorrect maintenance, wear and tear, battery, water composition, product abuse, or product misuse, whether performed by a contractor, service company, or the consumer. This warranty does not cover product damage caused by the following:

- Incorrect installation, inversions of supply pipes.
- Pressures or temperatures exceeding recommended limits.
- Improper manipulation, tampering, bad or lapsed maintenance.
- Foreign bodies, dirt or scale introduced by the water supply.

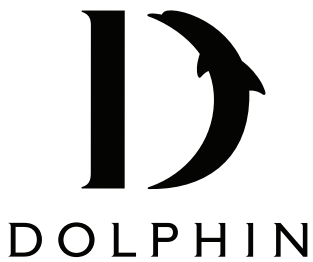

Dolphin Solutions Ltd

Southpoint, Compass Park, Bodiam,
Robertsbridge, TN32 5BS

Tel: +44 (0)1424 20 22 24

Fax: +44 (0)1424 205 200

info@dolphinsolutions.co.uk

www.dolphinsolutions.co.uk