

DBI900

DOLPHIN PANEL MOUNTED SENSOR TAP

INSTALLATION AND MAINTENANCE GUIDE



October 2019

D
DOLPHIN
BLUE

CONTENTS

2	Technical Data
3	Product Diagram
4-6	Installation Steps
7	Maintenance
7	Limited Warranty

TECHNICAL DATA

Item no:	DB 1900
Description:	Dolphin Sensor Tap
Power:	DC: 6v (4 x AA alkaline batteries) AC: 220V-240V 50/60Hz
Power consumption:	< 0.3MW
Sensing distance:	100mm
Water pressure:	0.5 - 7.0 bar
Temperature:	0.1 - 45°C
Diameter of inlet pipe:	G(1/2)"
Diameter of outlet pipe:	G(1/2)"
Flux:	< 0.15 (L/S)

PRODUCT DIAGRAM

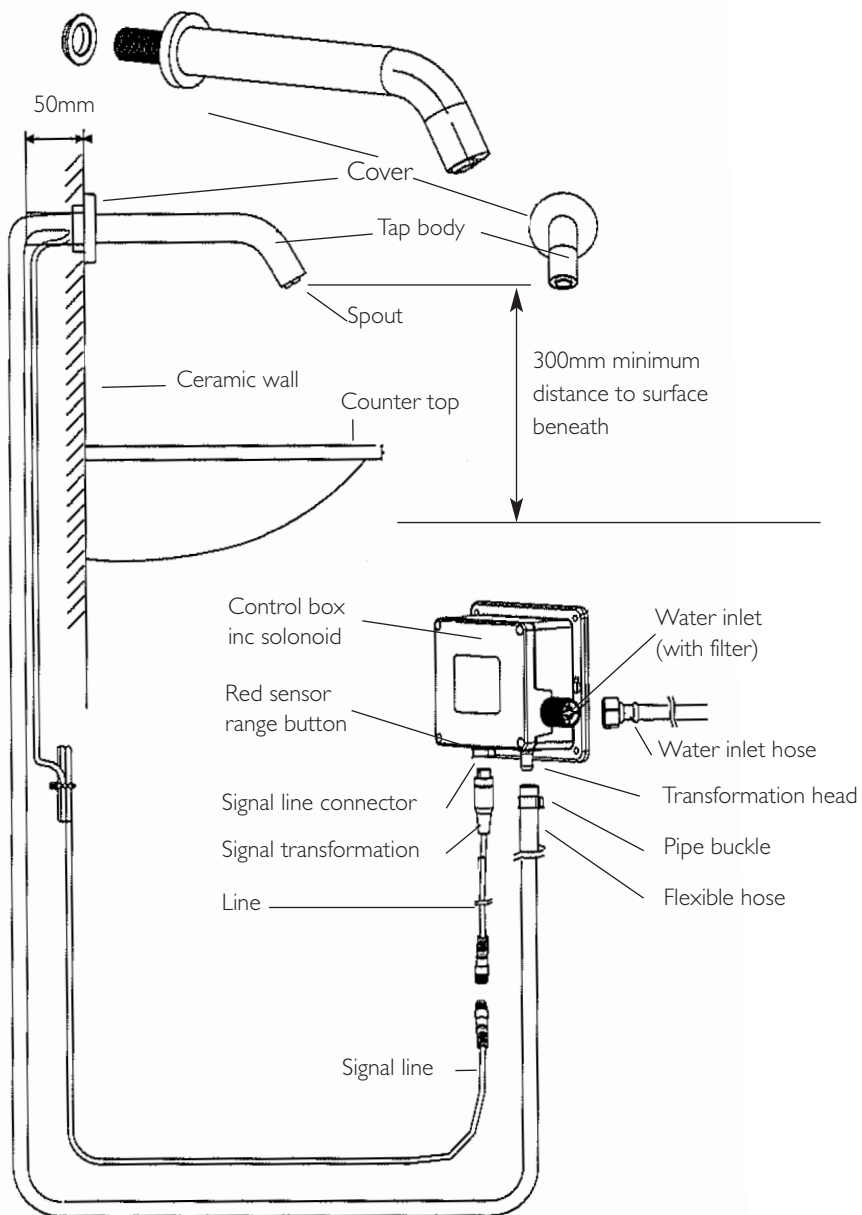

INSTALLATION STEPS

WARNING

- Highly reflective surfaces directly beneath the sensor of this product, in particular polished finish basin wastes/ strainers, will cause false activation of the infrared sensors and can result in malfunction. We recommend satin or matt finish products which can be found on our website.
- It is very important to allow permanent access to the mounting tail/nut of this product for future servicing and repair. Where this is not possible see our wall plate mounted products.

I. INSTALL TAP BODY TO THE WALL

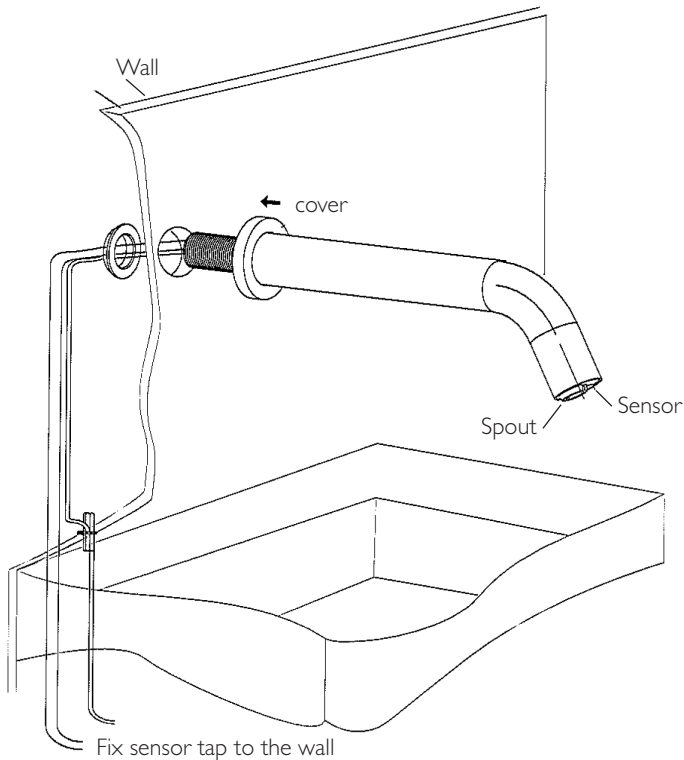

INSTALLATION STEPS

2. CONNECT POWER

AC: Connect the transformer

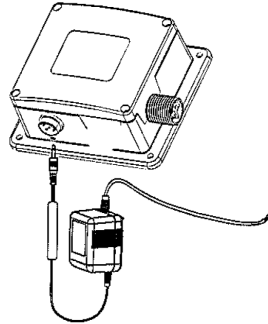

DC: put in 4 x AA alkaline batteries into the battery box

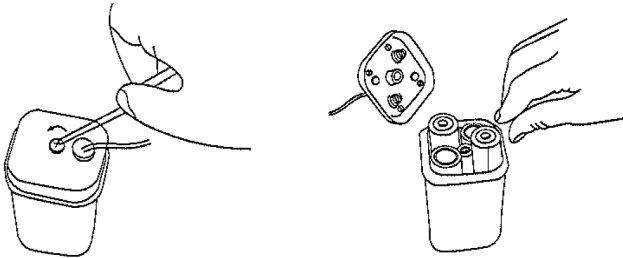

3. CONNECT WATER

Connect the water feed for the tap to the control box using the flexible hose, ensuring the clip is tightened properly.

Connect the water inlet hose to the control box

Note: Check for leaks

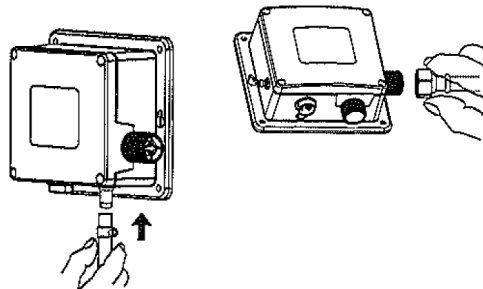

INSTALLATION STEPS

4. CONNECT SIGNAL CABLE

Connect the signal cable with the control box.
Screw tightly.

Note: Keep this cable dry and clean to ensure you do not have any faults.

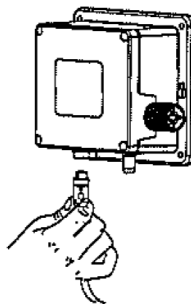

INSTALLING THE CONTROL BOX

Mount the control box onto the wall, using screws and plugs.

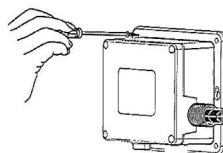

Note:

1. Turn off the water and power supply before installation.
2. Be sure to install the control box correctly.
3. For easy maintenance, choose a suitable place to install the control box. It must be less than 500mm from the basin. (Please check the picture opposite).
4. Ensure the tap spout when installed is 300mm from the surface beneath to ensure sensor has room to work.

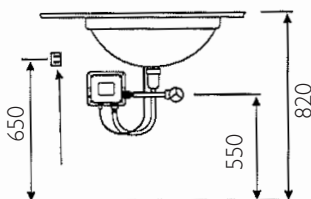

To adjust the sensor range, press the red button on the control box while placing a hand beneath the sensor at the desired activation height.

MAINTENANCE

AFTERCARE

Whilst modern plating techniques are used in the manufacture of this product, the surface will be affected if cleaned incorrectly. Surfaces should be maintained using a clean damp cloth, no abrasive agents or materials should be used or come into contact with the surface finish, or this will invalidate your guarantee.

LIMITED WARRANTY

Dolphin Solutions Ltd warrants that its electronic products will be free of defects in material and workmanship during normal use for two years from the date the product is purchased.

If a defect is found in normal use, Dolphin Solutions Ltd will, at its discretion, repair, provide a replacement part or product, or make appropriate adjustments. Damage caused by accident, misuse, or abuse is not covered by this warranty. Improper care and cleaning will void the warranty. Proof of purchase (original sales receipt) must be provided to Dolphin Solutions Ltd with all warranty claims.

Dolphin Solutions Ltd is not responsible for labor charges, installation, or other incidental or consequential costs other than those noted above. In no event shall the liability of Dolphin Solutions Ltd exceed the purchase price of the product. If you believe that you have a warranty claim, contact your Dolphin Solutions Ltd, Dealer or Plumbing Contractor. Please be sure to provide all pertinent information regarding your claim, including a complete description of the problem, the product, model number; the date the product was purchased, from whom the product was purchased and the installation date. Also include your original invoice.

DOLPHIN SOLUTIONS LTD AND/OR SELLER DISCLAIM ANY LIABILITY FOR SPECIAL, INCIDENTAL OR CONSEQUENTIAL DAMAGES.

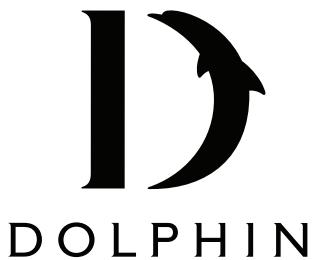

Dolphin Solutions Ltd

Southpoint, Compass Park, Bodiam,
Robertsbridge, TN32 5BS

Tel: +44 (0)1424 20 22 24

Fax: +44 (0)1424 205 200

info@dolphinsolutions.co.uk

www.dolphinsolutions.co.uk